



**BOSCH**

Invented for life

**Akustica, Inc.**

## Data sheet BMU563R

# Analog, HD Voice Silicon MEMS Microphone



### **BMU563R – Data Sheet**

Package type 5-pad LGA bottom port

Document revision 1.01a

Document release date 22 February 2017

Document number AKU-BMU563R-DS55

Technical Reference Code(s) 0 273 0A0 051

#### Notes

Specifications are subject to change without notice.

Product photos and pictures are for illustration purposes only and may differ from the real product's appearance.

## **BMU563R**

### **Analog, HD Voice Silicon MEMS Microphone**

#### **Key features**

- Single-ended analog voltage output
- Bottom port package
- Omni-directional silicon acoustic sensor
- Ultra-high performance: 66dB SNR
- Tight sensitivity tolerance: -38dB +/- 1 dB
- Robust against RF/EM interference. Au-plated lid for added RF immunity.
- Lead-free, surface-mountable and RoHS2 compliant
- Halogen-free compliant, IEC61249-2-21
- Thin profile, SMT packaging
- Industry standard package: 2.65 x 3.50 x 0.98 mm<sup>3</sup>

#### **Typical applications**

- Smartphones and mobile phones which require high quality acoustic performance
- Voice-activated entertainment systems, set-top-boxes, and remote controls
- Smart-home sensor hubs / clusters, and IoT acoustic sensor nodes
- Wearable accessories requiring small footprint and high performance
- Digital cameras
- Digital voice recorders
- Gaming consoles, and controllers
- Microphone arrays – multi-mic applications

#### **General description**

BMU563R is an HD Voice quality, bottom port, analog output MEMS semiconductor microphone. It is a microphone consisting of a MEMS acoustic sensor and an integrated circuit (IC) with a pre-amplifier, charge pump, and supporting circuitry in an industry standard package footprint of 2.65mm x 3.50mm x 0.98mm.

Designed specifically to provide ultra-high acoustic performance in a small footprint package, the BMU563R is ideal for use in mobile handsets, set-top-boxes, TV remote controls, and other applications requiring excellent acoustic performance for speech recognition and far field applications. The BMU563R offers 66dB signal-to-noise ratio (SNR), and uniform sensitivity matching of just +/-1dB between microphones. It also provides a flat super wideband frequency response delivering uniform audio capture across a broad audio spectrum.

BMU563R gold-plated metal lid package is immune to RF and Electromagnetic (EM) interferences, allowing for easy integration into wireless devices.

## Index of Contents

<b>1. ABSOLUTE MAXIMUM RATINGS</b> .....	<b>4</b>
<b>2. STANDARD OPERATING CONDITIONS</b> .....	<b>4</b>
<b>3. ELECTRICAL AND ACOUSTIC SPECIFICATIONS</b> .....	<b>4</b>
<b>4. TYPICAL DEVICE CHARACTERISTICS</b> .....	<b>5</b>
4.1 FREQUENCY RESPONSE	
4.2 $I_{DD}$ VS. $V_{DD}$	
4.3 SENSITIVITY VS. $V_{DD}$	
4.4 TOTAL HARMONIC DISTORTION	
<b>5. MECHANICAL SPECIFICATIONS</b> .....	<b>6</b>
<b>6. PIN-OUT AND CONNECTION DIAGRAMS</b> .....	<b>7</b>
6.1 PIN OUT	
6.2 TYPICAL APPLICATION SCHEMATIC	
<b>7. MANUFACTURING NOTES</b> .....	<b>8</b>
7.1 SOLDER REFLOW	
7.2 PART HANDLING	
7.3 PCB LAND PATTERN AND STENCIL PATTERN	
<b>8. RELIABILITY SPECIFICATIONS</b> .....	<b>11</b>
<b>9. PART MARKING INFORMATION</b> .....	<b>12</b>
<b>10. PACKAGING INFORMATION</b> .....	<b>12</b>
<b>11. ORDERING INFORMATION</b> .....	<b>13</b>
<b>12. LEGAL DISCLAIMER</b> .....	<b>14</b>
12.1 ENGINEERING SAMPLES	
12.2 PRODUCT USE	
12.3 APPLICATION EXAMPLES AND HINTS	
<b>13. DOCUMENT HISTORY AND MODIFICATION</b> .....	<b>15</b>

## 1. Absolute maximum ratings

Supply Voltage, $V_{DD}$ to GND	5.5V
ESD Tolerance	
Human Body Model	2000V
Machine Model	200V
Storage Temperature Range	-40°C to 105°C

## 2. Standard operating conditions

Operating Temperature Range	-40°C to 100°C
Supply Voltage ( $V_{DD}$ )	1.62V to 3.6V

## 3. Electrical and acoustic specifications

Unless otherwise noted, test conditions are:

$V_{DD} = 1.8V$

$T_a = 25^{\circ}C$

$RH = 50\%$

Parameter	Test Conditions	Min	Typ	Max.	Unit
		.	.	.	
Directivity		Omni-directional			
Signal to Noise Ratio (SNR10)	$f_{in} = 1$ kHz, A-weighted, 20Hz – 10kHz.		66		dB
Signal to Noise Ratio (SNR20)	$f_{in} = 1$ kHz, A-weighted, 20Hz – 20kHz		64.3		dB
Low Frequency Corner	-3dB from 1kHz sensitivity value	55	70	85	Hz
Upper Frequency Corner	+3dB from 1kHz sensitivity value		12.5		kHz
Sensitivity <sup>1</sup>	1kHz, 94dB SPL	-39	-38	-37	dBV/Pa
Total Harmonic Distortion (THD)	@ 94dB SPL, $f_{in} = 1$ kHz			0.5	%
	@ 116dB SPL, $f_{in} = 1$ kHz <sup>1</sup>			3	
Acoustic Overload Point (AOP)	< 10% THD at max sensitivity		123		dB SPL
Power Supply Rejection (PSR)	100mVpp, $f = 217$ Hz, square wave, A-weighted 20Hz – 20kHz		-	100	dBV(A)
Power Supply Rejection Ratio (PSRR)	200mVpp, $f = 1$ kHz, sine wave		67		dB
Current Consumption <sup>1</sup>	No load		205	275	$\mu$ A
Output Impedance				200	$\Omega$
Sensitivity loss across voltage	Change in sensitivity over 3.6V to 1.62V		0		dB
Part-to-part phase matching	From nominal @ 1kHz		$\pm 4$		$^{\circ}$
Polarity	Increasing sound pressure	Increasing output voltage			

Note 1: Parameter 100% tested

## 4. Typical device characteristics

### 4.1 Frequency Response

(Measured frequency response normalized to 1kHz)

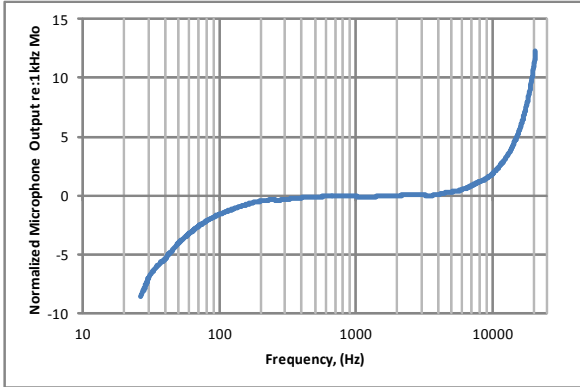

### 4.2 I<sub>DD</sub> vs. V<sub>DD</sub>

(Measured current consumption relative to supply voltage)

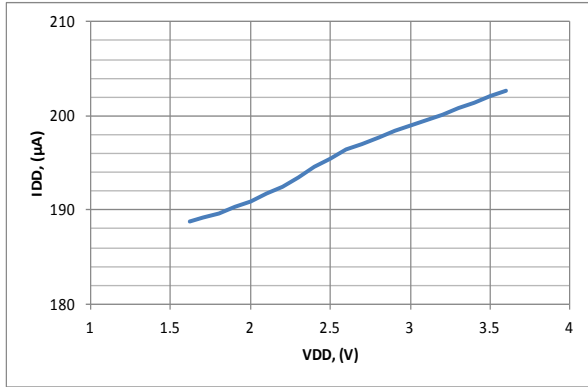

### 4.3 Sensitivity vs. V<sub>DD</sub>

(Measured sensitivity changes relative to supply voltage)

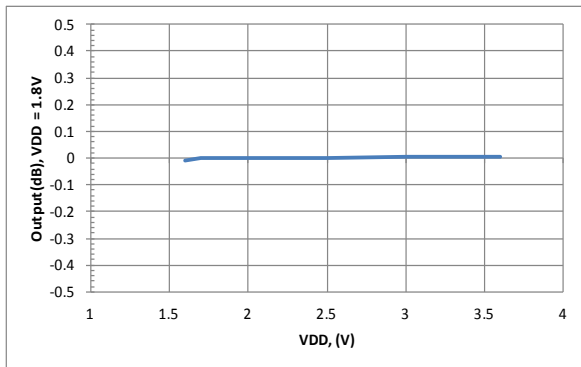

### 4.4 Total Harmonic Distortion

(Measured THD relative to speaker output pressure level)

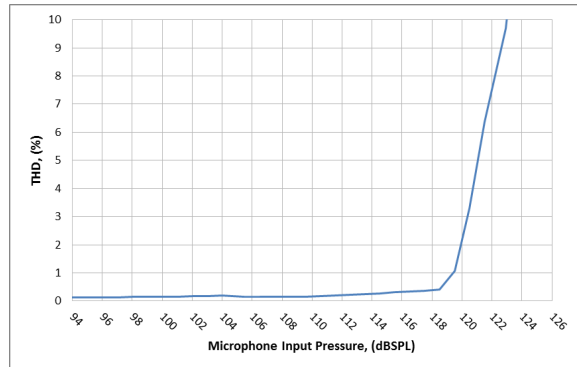

## 5. Mechanical Specifications

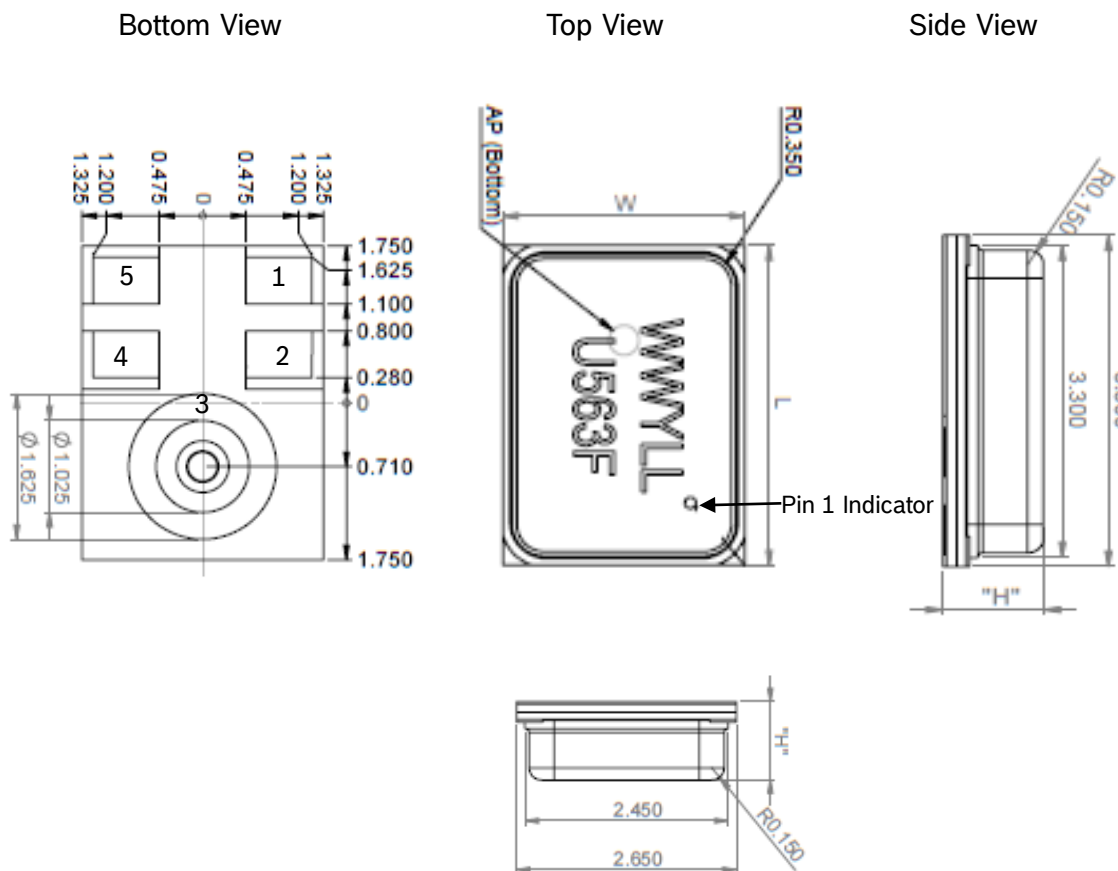

Item	Dimension	Tolerance	Units
Length (L)	3.50	$\pm 0.10$	mm
Width (W)	2.65	$\pm 0.10$	mm
Height (H)	0.98	$\pm 0.10$	mm
Acoustic Port (AP)	0.325	$\pm 0.05$	mm
Planarity	Top/Bottom	$\pm 0.05$	mm

All dimensions in mm  
 Tolerance  $\pm 0.05$ mm unless otherwise specified

## 6. Pin-Out and connection diagrams

### 6.1 Pin-Out

(As viewed from **bottom** of package)

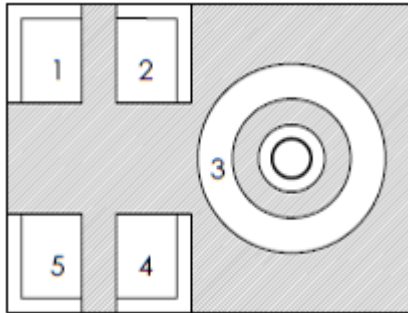

Pin	Name	Function
1	V <sub>OUT</sub>	Analog output voltage
2	GND	Ground
3	GND	Ground
4	GND	Ground
5	V <sub>DD</sub>	Power

### 6.2 Typical Application Schematics

#### 6.2.1 3-wire mode

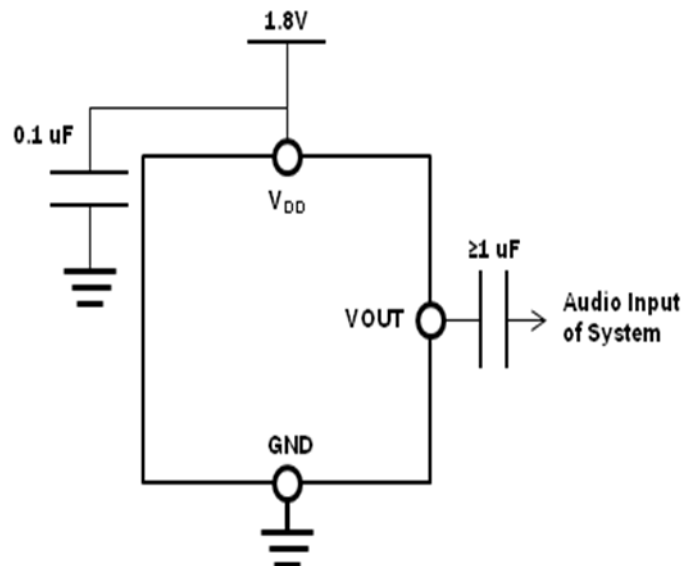

## 7. Manufacturing notes

### 7.1 Solder Reflow

Typical solder reflow profile

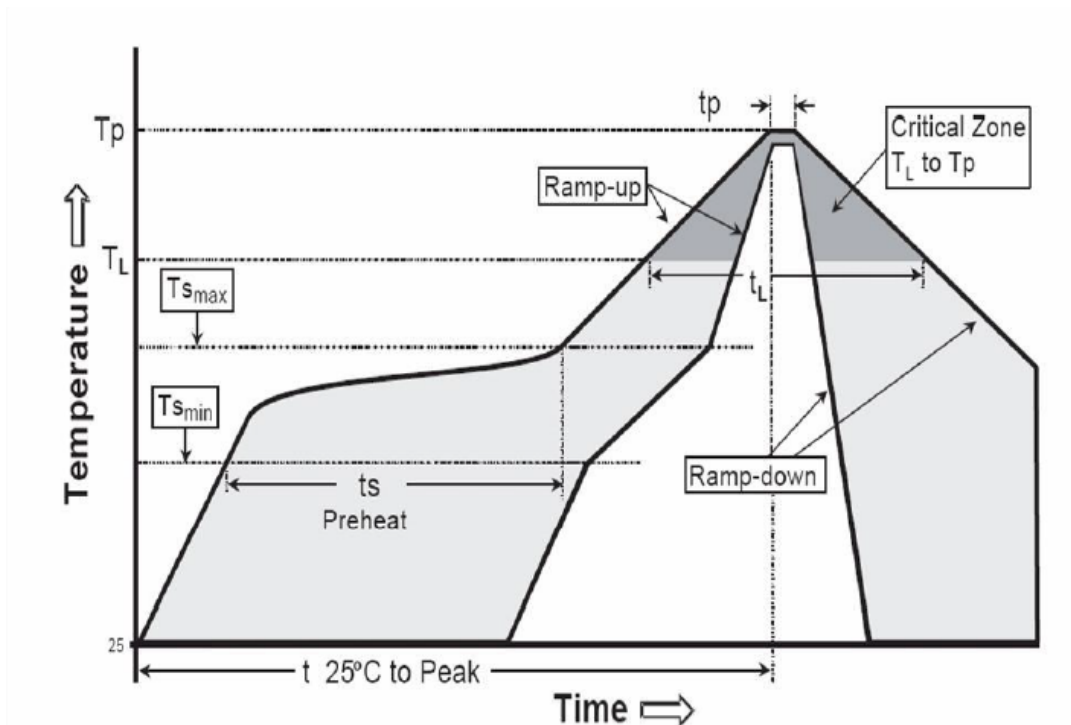

Description	Parameter	Pb free
Average ramp-up rate	$T_L$ to $T_P$	max. 3°C/s
Time between $T_{smin}$ (150°C) and $T_{smax}$ (200°C)	$t_s$	60s – 120s
Time above liquidous temperature $T_L$ (217°C)	$t_L$	60s – 90s
Peak temperature	$T_P$	max. 260°C
Time at $T_P$	$t_p$	max. 20s
Average ramp-down rate	$T_P$ to 25°C	max. 6°C/s

Note: It is recommended to fine-tune the reflow process to optimize for variations in materials, environment, handling, PCB board size and thickness, etc.

Please refer to AN60-Handling, Soldering, and Mounting Instructions for more detailed information and precautions.



## 7.2. Microphone Handling

Although the microphone may not appear damaged immediately due to inappropriate handling, there can be long term effects that affect the lifetime of the component.

Rule of thumb: The microphone is an artificial ear so treat it like your own ear.

- Do not blow air into the acoustic port of the microphone for any reason. Do not subject it to pressurized air
  - e.g. when cleaning the board or other components on the same board
- Do not apply vacuum to the acoustic port of the microphone
- Do not insert liquids
  - If populated circuit boards are washed, the microphone must be protected
- Do not insert dust
  - The production facilities must be clean
  - e.g. if PCB routing/sawing is done close to the microphone after SMT assembly and reflow
- Do not insert any objects
  - If assembly or rework is done manually, care must be taken that the tools cannot enter the microphone sound port
  - It is best to choose tool size so that it does not fit through the sound port of the microphone
- Do not cover the acoustic port with tape when heating during assembly or reflow
- Do not apply extreme mechanical stresses on the microphone, including mechanical shocks above 10kG or compression of the microphone package.
- After a bottom port microphone has been assembled on a circuit board, protect the sound port (now on the other side of the board) from dust, liquids, and other foreign materials as well as any tools and pressurized air.

### ESD Handling Procedures



Follow CMOS handling procedures with MEMS microphones. Handle the microphone with proper workplace grounding to include wrist straps and ionized airflow over open trays and reels of microphones. Do not hot-swap/hot-plug during testing. Device pins have ESD ratings of 2kV/200V for HBM/MM respectively.

### 7.3 PCB Land Pattern and Stencil Pattern Examples

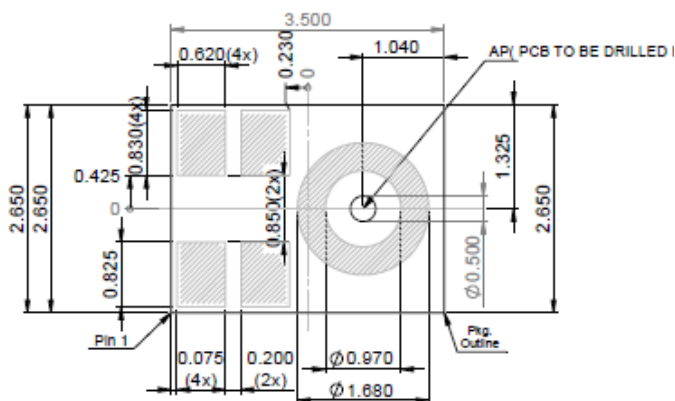
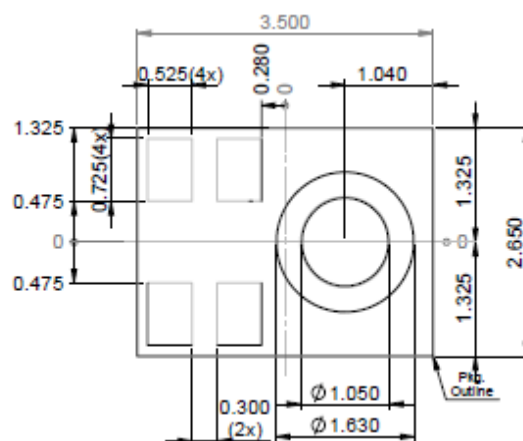
**Land Pattern**

**Stencil Pattern**

Note: the aperture of the stencil pattern may require adjustment / optimization based on the thickness of the stencil.

Please refer to AN60-Handling, Soldering, and Mounting Instructions for more detailed information and precautions.

## 8. Reliability Specifications

The microphone sensitivity after stress must deviate by no more than 3dB from the initial value.

	Test	Test Condition	Standard
1	Cold Temp Operation	Temperature = -40°C, 1000 hours (with bias)	IEC 60068-2-1
2	Hot Temp Operation	Temperature = 105°C, 1000 hours (with bias)	IEC 60068-2-2
3	Humidity Operation	Temperature = 85°C, RH = 85%, 1000 hours (with bias)	JESD22-A101-B
4	Cold Temp Storage	Temperature = -40°C, 1000 hours (without bias)	IEC 60068-2-1
5	Hot Temp Storage	Temperature = 105°C, 1000 hours (without bias)	IEC 60068-2-2
6	Humidity Storage	Temperature = 85°C, RH = 85%, 1000 hours (without bias)	JESD22-A101-B
7	Thermal Cycle	100 Cycles, -40 to +125C, 15min soaks, <30sec ramps	IEC 60068-2-4
8	Vibration	Sinusoidal Vibration, 20Hz-2000Hz, 4min sweeps, 16min along each of 3 axis, amplitude 3 limits of 20G and 0.06"	Mil-Std-883E, Test A
9	Mechanical Shock	10,000G shocks, 5 impacts along each of 6 axes	MIL-STD-883E
10	Drop Test, Standard	Using 150gm aluminum fixture, 3 drops along each of 6 axes (total 18 drops) from 1.5m height onto concrete drop surface.	IEC 60068-2-32
11	Drop Test, Air Hammer	1.0m height, drops onto polished granite using 165g aluminum fixture. 20x drops, starting at 1st drop, with 1x drop increment	Custom
12	ESD (HBM)	+/- 2000V, 1 discharge for each polarity, 11 pin combinations, 22 total discharges per microphone	JESD22-A114-B
13	ESD (MM)	+/- 200V, 1 discharge for each polarity, 11 pin combinations, 22 total discharges per microphone	JESD22-A115-A
14	ESD	+/- 8kV, contact discharge to lid with DUT grounded	IEC 61000-4-2
15	Moisture Sensitivity Level 1	24 hour bake at 125°C, followed by 168 hours at 85°C, 85%RH, followed by 3 passes solder reflow (MSL Level 1)	JSTD020D-01
16	Reflow Solder	3 pass reflow, peak temperature = 260°C, time duration - see reflow profile in section 7	JSTD020D-01

## 9. Part marking information

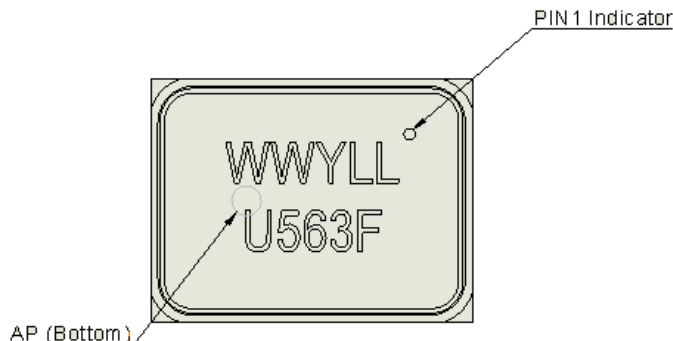

Line 1: WWYLL (WW = Work Week | Y = Year | LL= Lot Number Processed During Work Week)  
Line 2: U563 (U = Microphone, 563 = Part Code | F = Assembly Facility)

## 10. Packaging information

### 10.1 Tape Specification

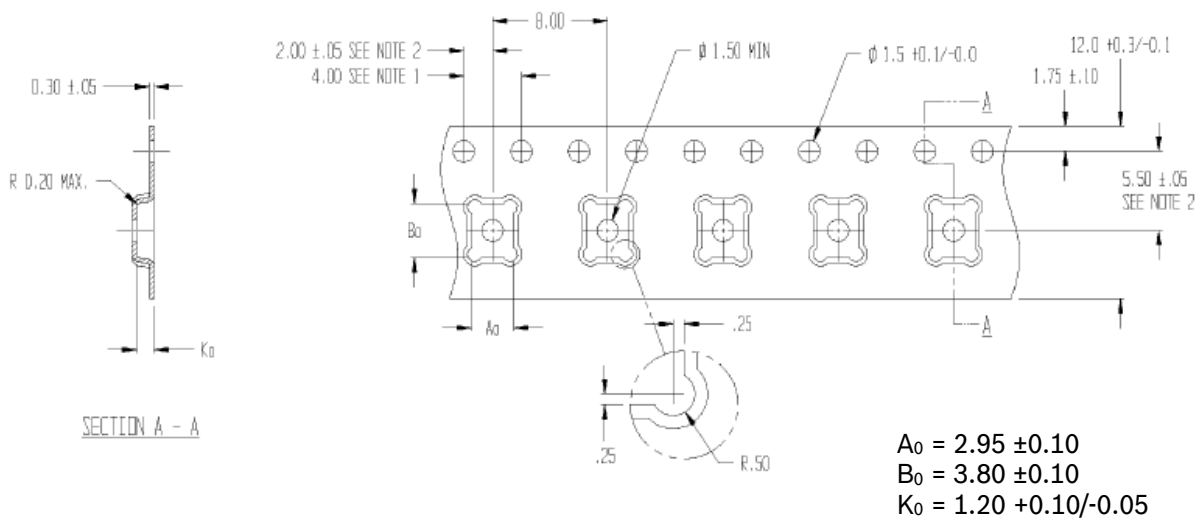

#### Notes:

1. 10 sprocket hole pitch cumulative tolerance +/- 0.2
2. Camber in compliance with EIA-481
3. Pocket position relative to sprocket hole measured as true position of pocket, not pocket hole
4.  $A_0$  and  $B_0$  are calculated on a plane at a distance of "R" above the bottom of the pocket.

## 10.2 Component Orientation

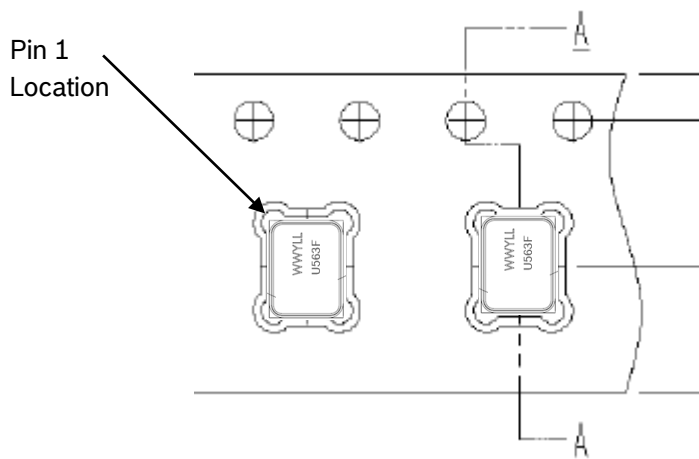

## 11. Ordering information

Order Number	Sensitivity Tolerance (dB)	RF Filter	Part Code	Package	Shipping Method	Standard Quantity
0 273 0A0 051	+/- 1	Yes	U563	5-Pad LGA	13" Reel	5,900

## 12. Legal Disclaimer

### 12.1 Engineering samples

Engineering Samples are marked with an asterisk (\*) or (e). Samples may vary from the valid technical specifications of the product series contained in this data sheet. They are therefore not intended or fit for resale to third parties or for use in end products. Their sole purpose is internal client testing. The testing of an engineering sample may in no way replace the testing of a product series. Akustica assumes no liability for the use of engineering samples. The Purchaser shall indemnify Akustica from all claims arising from the use of engineering samples.

### 12.2 Product use

Akustica products are developed for the consumer goods industry. They may only be used within the parameters of this product data sheet. They are not fit for use in life-sustaining or security sensitive systems. Security sensitive systems are those for which a malfunction is expected to lead to bodily harm or significant property damage. In addition, they are not fit for use in products which interact with motor vehicle systems.

The resale and/or use of products are at the purchaser's own risk and his own responsibility. The examination of fitness for the intended use is the sole responsibility of the Purchaser.

The purchaser shall indemnify Akustica from all third party claims arising from any product use not covered by the parameters of this product data sheet or not approved by Akustica and reimburse Akustica for all costs in connection with such claims.

The purchaser must monitor the market for the purchased products, particularly with regard to product safety, and inform Akustica without delay of all security relevant incidents.

### 12.3 Application examples and hints

With respect to any examples or hints given herein, any typical values stated herein and/or any information regarding the application of the device, Akustica hereby disclaims any and all warranties and liabilities of any kind, including without limitation warranties of non-infringement of intellectual property rights or copyrights of any third party. The information given in this document shall in no event be regarded as a guarantee of conditions or characteristics. They are provided for illustrative purposes only and no evaluation regarding infringement of intellectual property rights or copyrights or regarding functionality, performance or error has been made.

### 13. Document history and modification

Rev. No	Chapter	Description of modification/changes	Date
0.52		Released preliminary datasheet	12-May-2016
0.75	11	Added ordering number	01-June-2016
0.75a	All	Applied new datasheet template	29-June-2016
1.0a	8	Updated table	11-Nov-2016
1.01a	3	Added SNR bandwidth	22-Feb-2017

Akustica, Inc.  
2555 Smallman Street, Suite 200  
Pittsburgh, PA / USA 15222  
(412) 390-1730

[sales@akustica.com](mailto:sales@akustica.com)  
[www.akustica.com/contact.asp](http://www.akustica.com/contact.asp)

Modifications reserved | Printed in USA  
Specifications subject to change without notice